



**S&P USA**

**Qty:** 1  
**Tag:**  
**Project:** Direct Drive Explosion  
 Optimizer Version 2.0  
 Printed: 2024-07-07

**STXD8**

**Centrifugal Upblast Roof Exhauster-Direct Drive Motors**

**STANDARD FEATURES:**

Heavy Gauge Aluminum Construction • Non-Overloading Aluminum Curved Backward Inclined Wheel • Integral Deep Spun Inlet • Disconnect standard with ODP and TE single speed motors • AMCA Air, Sound, and FEI Licensed • cULus 705 Certified • 5 Year Fan and 1 Year Motor Warranty

**Performance**

Fan RPM	Flow (CFM)	SP (in W.G.)	Power (HP)	FEP Actual (kW)	FEI	SE	TE	FPM (TS)	FPM (OV)
1745	868	.151	.11	0.14	1.33	19%	31%	4683	1268

**Altitude (Feet):** n/a      **Temperature (Fahrenheit):** n/a      **Density (Lb/Ft3):** .075

**Motor Information: (Wired for 115V)**

HP	RPM	Volts/PH/Hz	Enclosure	Efficiency	Mounted
.25	1725	115V/208V-230V/1PH/60HZ	EXPLOSION PROOF	STANDARD	YES

**Sound Power Levels - Octave Bands**

LwA	dBA	Sones	1	2	3	4	5	6	7	8
73	62	10.8	64	65	77	69	62	66	64	52

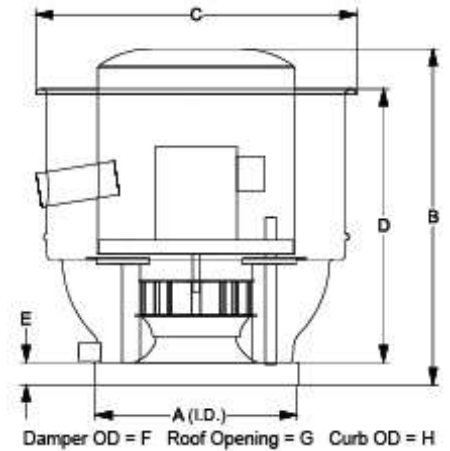

**Dimensions (Inches)**

A	B	C	D	E	F	G	H	I	J	K	L	M	N	O	P	Q	R	S	T	U	V	W	X	Y
18.00	25.31	28.63	20.31	2.00	12.00	13.50	16.50		13.50	17.75														

Note: Accessories may effect dimensions shown.

**Avg. Shipping Weight (Lbs)\*:** 98

\*Includes fan, motor, and packaging.



in W.G.

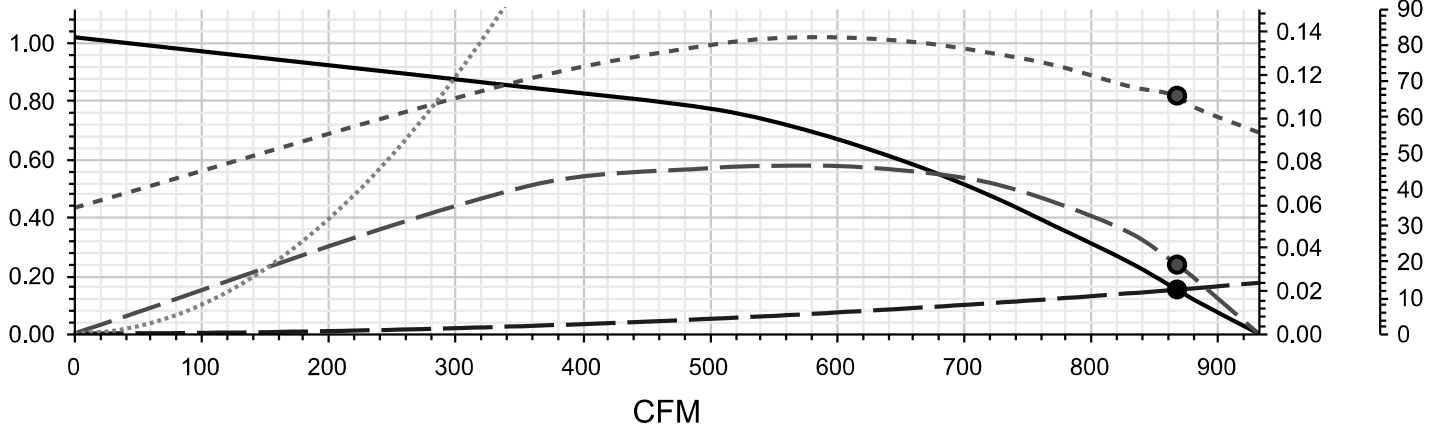

———— Fan Curve    ——— System Curve    - - - - - Horsepower    ——— Static Efficiency    ..... Stall Curve

**Accessories:**

16-1/2" SQ GALV SF CURB 8" HIGH W.D.T. • LABEL UL/CUL 705 LISTED POWER VENT (709J) • BIRD SCREEN, STXB/STXD 06-10 MOUNTED