



S&P USA

Qty: 1
Tag:
Project: Direct Drive Explosion
 Optimizer Version 2.0
 Printed: 2024-07-07

STXD1033-50

Centrifugal Upblast Roof Exhauster-Direct Drive Motors

STANDARD FEATURES:

Heavy Gauge Aluminum Construction • Non-Overloading Aluminum Curved Backward Inclined Wheel • Integral Deep Spun Inlet • Disconnect standard with ODP and TE single speed motors • AMCA Air, Sound, and FEI Licensed • cULus 705 Certified • 5 Year Fan and 1 Year Motor Warranty

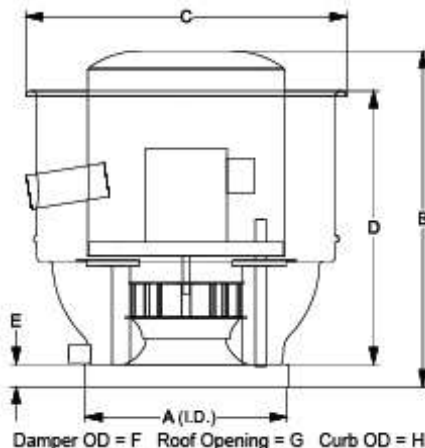

Performance

Fan RPM	Flow (CFM)	SP (in W.G.)	Power (HP)	FEP Actual (kW)	FEI	SE	TE	FPM (TS)	FPM (OV)
1415	1195	.014	.125	0.15	1.19	2%	17%	4445	1259

Altitude (Feet): n/a **Temperature (Fahrenheit):** n/a **Density (Lb/Ft3):** .075

Motor Information: (Wired for 115V)

HP	RPM	Volts/PH/Hz	Enclosure	Efficiency	Mounted
.333	1725	115V/208V-230V/1PH/60HZ	EXPLOSION PROOF	STANDARD	YES

Sound Power Levels - Octave Bands

LwA	dBA	Sones	1	2	3	4	5	6	7	8
73	61	10.7	65	70	77	68	64	65	60	50

Dimensions (Inches)

A	B	C	D	E	F	G	H	I	J	K	L	M	N	O	P	Q	R	S	T	U	V	W	X	Y
18.00	25.31	28.63	20.31	2.00	12.00	13.50	16.50		13.50	17.75														

Note: Accessories may effect dimensions shown.

Avg. Shipping Weight (Lbs)*: 101

*Includes fan, motor, and packaging.



in W.G.

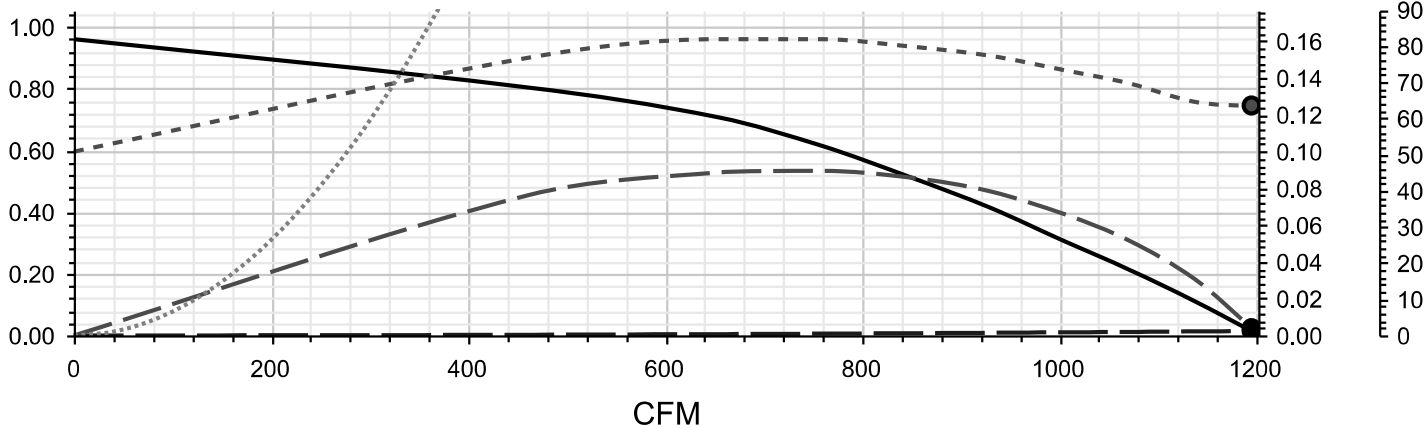

———— Fan Curve ——— System Curve - - - - - Horsepower — — — Static Efficiency Stall Curve

Accessories:

16-1/2" SQ GALV SF CURB 8" HIGH W.D.T. • LABEL UL/CUL 705 LISTED POWER VENT (709J) • BIRD SCREEN, STXB/STXD 06-10 MOUNTED