

# Tube Axial Duct Fans

## MODEL DF – TUBE AXIAL DUCT FAN – DIRECT DRIVE



### APPLICATION

Designed for use in dry maximum 104°F environments to economically remove fumes, dust or smoke. Suitable for use in the following applications:

- air make-up systems where motor must be located in the airstream
- hazardous locations when equipped with explosion proof motor
- harsh, dry environments when equipped with mill and chemical duty motors and special coating.

### FEATURES AND BENEFITS

- Standard propellers are non-sparking cast aluminum.
- Fan housing is all welded, heavy gauge steel construction.
- Motors are high quality industrial grade available in single or three phase - totally enclosed or explosion proof.

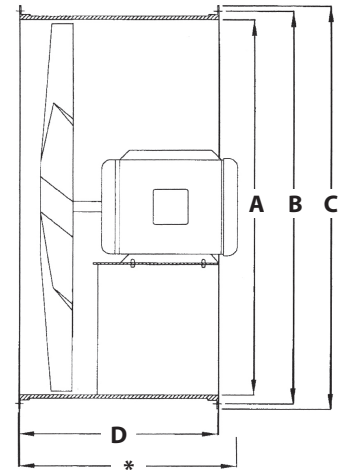
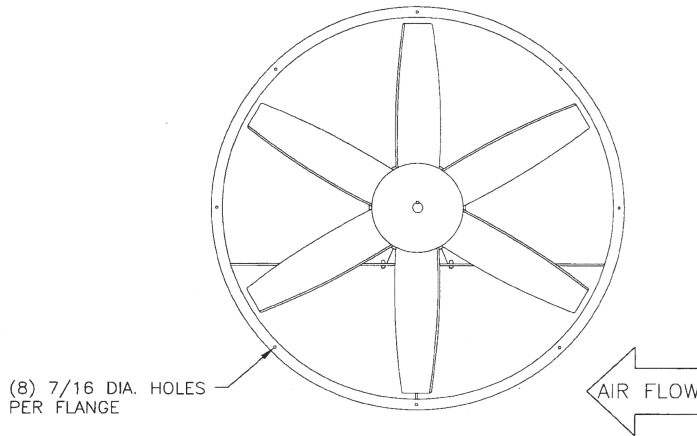

\*Dimensions vary with motor.

### DIMENSIONS (subject to change without notice)

MODEL	A	B	C	D	HP
DF-12	12"	13 1/8"	14"	14"	1/4-3/4
DF-18	18"	19 1/8"	20"	14"	1/4-1
DF-24	24"	25 3/4"	27"	18"	1/4-3
DF-27	27"	28 3/4"	30"	18"	1/2-2
DF-30	30"	31 3/4"	33"	18"	1/2-3
DF-34	34"	35 3/4"	37"	18"	1 1/2-5
DF-36	36"	37 7/8"	39"	18"	2-3
DF-42	42"	43 9/16"	45"	18"	1-5
DF-48	48"	49 5/8"	51"	18"	3-5
DF-60	60"	61 5/8"	63"	36"	7 1/2-15

## MODEL DF – TUBE AXIAL DUCT FAN – DIRECT DRIVE PERFORMANCE DATA

Blade Dia.	Model	Prop	HP	RPM	Free Air	CAPACITY C.F.M.						
						1/8" SP	1/4" SP	3/8" SP	1/2" SP	3/4" SP	1" SP	1-1/4" SP
12"	DF-12-1/4	CA101	1/4	1725	1180	930	520	---	---	---	---	---
	DF-12-1/2	CA101	1/2	3450	1875	1650	1400	1320	1250	1100	660	---
	DF-12-3/4	CA102	3/4	3450	2044	1960	1920	1820	1650	1500	1100	---
18"	DF-18-1/4	CA105	1/4	1725	3450	3050	2500	1200	---	---	---	---
	DF-18-1/3	CA232	1/3	1725	3375	3000	2600	2000	1400	---	---	---
	DF-18-1/2	CA161	1/2	1725	4150	3850	3150	2800	1700	---	---	---
	DF-18-1	CA107	1	1725	4600	4375	4080	3600	3000	2100	1550	---
24"	DF-24-1/4	CA130	1/4	1725	5200	4200	2820	1050	---	---	---	---
	DFL-24-1/3	CA109	1/3	1140	4975	4690	4250	3920	2850	---	---	---
	DF-24-1/2	CA108	1/2	1725	6510	5880	5200	4150	3100	1800	---	---
	DFL-24-3/4	CA191	3/4	1140	6900	6450	6265	5600	3300	---	---	---
	DF-24-1	CA109	1	1725	7425	7000	6350	5850	5000	3300	1775	---
	DF-24-2	CA162	2	1725	9525	9196	8810	8360	7980	6960	3000	---
	DF-24-3	CA191	3	1725	10500	9800	9500	9100	8700	7800	5000	3600
27"	DF-27-1/2	CA121	1/2	1725	7550	6820	6000	5100	4000	2000	---	---
	DF-27-1	CA110	1	1725	9600	9000	8400	7775	7050	4800	---	---
	DF-27-2	CA111	2	1725	11500	11200	10700	10000	9300	8000	5900	3600
30"	DF-30-1/2	CA112	1/2	1725	8980	7650	6300	5400	4350	2300	---	---
	DFL-30-3/4	CA113	3/4	1140	10440	9750	8750	7640	6000	---	---	---
	DF-30-2	CA250	2	1725	12000	11250	10450	9600	8700	6000	4100	---
	DFL-30-2	CA115	2	1140	14000	13750	12900	11850	10450	2500	---	---
DF-30-3	CA113	3	1725	16000	15350	14700	13850	12900	10200	8000	6000	
34"	DF-34-1 1/2	CA116	1 1/2	1725	13350	12100	10000	9100	7300	---	---	---
	DF-34-2	CA188	2	1725	14850	13600	12100	10450	8800	4000	---	---
	DFL-34-2	CA163	2	1140	15950	15100	13800	12500	11400	---	---	---
	DFL-34-3	CA123	3	1140	19300	18290	17230	16000	14800	11614	4000	---
	DF-34-5	CA128	5	1725	21000	19850	18900	18200	17500	14850	9300	---
36"	DFL-36-2	CA117	2	1140	17620	16500	15200	13620	12300	8500	---	---
	DF-36-3	CA134	3	1725	18500	17700	15700	15100	13900	11500	8550	---
	DFL-36-3	CA221	3	1140	20500	19500	18500	17100	15850	11600	6500	---
42"	DFL-42-1	CA165	1	870	15800	15200	13480	12310	5800	900	---	---
	DFL-42-2	CA165	2	1140	17964	17277	15326	13990	12351	7600	---	---
	DFL-42-2	CA119	2	870	22040	21000	20500	18500	15000	6000	---	---
	DFL-42-3	CA239	3	1140	24500	23150	23000	22000	19650	14000	10000	---
	DFL-42-5	CA119	5	1140	28970	27960	26840	25700	24200	19500	13800	2000
48"	DFL-48-3	CA137	3	1140	28600	26500	24400	22000	20000	15900	11000	---
	DFL-48-3	CA139	3	870	28700	26500	24200	21600	18500	10000	---	---
	DFL-48-5	CA138	5	870	33000	31500	29750	27650	25300	18000	---	---
60"	DFL-60-7 1/2	CA228	7 1/2	870	47000	45500	43600	41000	38700	33000	24000	---
	DFL-60-10	CA143	10	870	57200	54400	51000	48500	45000	38000	29500	---
	DFL-60-15	CA227	15	870	60750	58875	56625	54375	51750	47625	42000	34500

### OPTIONAL ACCESSORIES

- Companion flanges
- Horizontal support legs
- Horizontal or vertical support brackets
- Inlet or outlet guards – OSHA compliant
- Inspection door
- Epoxy or urethane coatings