



INSTALLATION, OPERATION & MAINTENANCE MANUAL AXIAL UPBLAST FANS RTA, RWTA, RHTA, RB, RD

The purpose of this manual is to aid in the proper installation and operation of the fans. These instructions are intended to supplement good general practices and are not intended to cover detailed instruction procedures. It is the responsibility of the purchaser to assure that the installation and maintenance of this equipment is handled by qualified personnel.

Inspect all shipments carefully for damage. **THE RECEIVER MUST NOTE ANY DAMAGE ON THE CARRIERS BILL OF LADING AND FILE A CLAIM IMMEDIATELY WITH THE FREIGHT CO.**

INSTALLATION

1. All roof fans are to be installed vertically on suitable roof curbs. For specific dimensions see the submittal drawings.
2. The fans, when lifted, should be lifted using lifting lugs or proper rigging techniques and should never be lifted by the motor, belt tube, damper frame, wind band or accessories.
3. Caution: The fan contains rotating parts and requires electrical service. Appropriate safety precautions should be taken during installation, operation and maintenance.
4. Warning: Do not install or operate this fan in an environment where combustible or flammable materials, gasses or fumes are present unless it was specifically designed and manufactured for that application.
5. A qualified electrician must do all electrical work, in accordance with all applicable electrical codes.
6. Prior to wiring ensure the power supply is locked in the **OFF** position and that the motor nameplate voltage and the supply voltage match.
7. Be sure to keep all wiring clear of any rotating parts.
8. Before starting the fan ensure the wheel rotates freely.
9. Tighten all nuts, bolts and set screws to the proper torque settings (see chart) and ensure butterfly dampers operate freely.
10. On belt driven fans assure that the belts are aligned and tensioned correctly.
11. Ensure that all protective guards and other safety devices are installed properly prior to fan start up.
12. If installed on a sloped roof then a sloped roof curb must be used so the fan is vertical
13. Install a bead of caulking around the perimeter of fan where flanges meet.

Wiring Instructions

A qualified electrician in accordance with all local and National Electrical Codes should do all wiring. **Lock off all power sources before any wiring is to be performed.** Leave enough slack in the wiring to allow for motor movement when adjusting the belt tension. Excess wire must be restrained in order to prevent it from entanglement with moving parts. Disconnect switches are recommended and should be located near the fan in order to, swiftly cut off power in case of an emergency and maintain complete control of the power source. Some motors may have to be removed in order to make the connections in the motor terminal box. Follow the wiring diagrams on the motor nameplate.

1. Curb Mounted Fans
 - Extend the proper gauge wire to the fan motor.
 - Restrain excess wire from entanglement with moving parts.

OPERATION

Pre Start Inspection

- Lock out all power sources
- Inspect all fasteners and set screws and tighten as required
- Inspect belt alignment and tension
- Confirm power source voltage and motor voltage are the same and that the motor is wired correctly
- Rotate the fan blade to ensure that neither the fan blade nor the belts come into contact with the housing
- Inspect the fan and the ductwork to ensure they are free of debris
- Check to ensure that all guards and accessories are securely mounted
- Check to be sure the propeller rotation is correct

Start Up

Turn the fan on and inspect for the following.

- Direction of rotation
- Improper motor amperage
- Excessive Vibration
- Unusual Noise
- Improper belt tension or alignment

If a problem is discovered shut off the fan and refer to the section on troubleshooting to discover the cause of the problem. The fan should be inspected after 30 minutes, 8 hours and 24 hours of operation to ensure all fasteners are tight and belts are properly tensioned and aligned.

MAINTENANCE

WARNING

Disconnect and secure to the **OFF** position all electrical power to the fan prior to inspection or servicing. Failure to comply with this safety precaution could result in serious injury or death.

1. Ventilators should be checked at least once a year. For critical or severe applications a routine check every two or three months is suggested.
2. When removing or installing a belt do not force the belt over the sheave. Loosen the motor mount so that the belt can be easily slipped over the sheave.

3. The belt, on belt driven units, should be removed and carefully checked for cracks, ply separation or irregular wear. A small irregularity in the contact surface of the belt will result in noisy operation. If any of these defects are apparent the belt should be replaced. At the same time check the sheaves for chips, dents or rough surfaces that could damage the belt.
4. The correct belt tension is important. Too tight a belt will result in excess bearing pressure, which can cause premature bearing failure and may cause the motor to overload, too loose a belt will result in slippage, which will burn out belts. Proper belt deflection should be 1/64" (half way between sheaves centers) for each inch of belt span when a force of approximately five lbs. is applied.
5. The belt alignment should be checked to be sure that the belt is running perpendicular to the rotating shaft. Motor and drive shafts must be parallel.
6. A periodic inspection of all fasteners should be carried out to ensure that they have not loosened due to vibration. Particular attention should be paid to fasteners attaching the wheel to the shaft and those attaching the shaft to the bearings.
7. The standard pillow blocks on belt driven fans are factory lubricated. These bearings should be lubricated on a semi annual basis (more frequently in severe applications) using a high quality lithium based grease. With the unit running add grease very slowly, using a manual grease gun, until a slight bead of grease forms at the seal. Be careful not to unseat the seal by over lubricating or by using excessive pressure. When the bearings are obstructed from view use no more than three injections with a hand operated grease gun
8. Dust and dirt on the exterior surface of the motor, butterfly dampers and the entire fan wheel, should be removed at intervals as determined by the severity of the environment.
9. For additional safety information refer to AMCA publication 410-96, Safety Practices for Users and Installers of Industrial and Commercial Fans

Belt and Pulley Replacement

In the course of regular maintenance the belts and pulleys may have to be changed and or adjusted The recommended procedure is as follows:

- Remove fan from the curb (RB)
- Do not change the pulley pitch diameter in order to tension the belts. This will result in a change in the fan speed.
- Loosen the nuts on the motor plate or motor in order to reduce the belt tension such that the belts will easily slip over the pulleys. Never force the belts over the rim of the pulley.
- Remove the lower pulley access door (RTA, RWTA)
- Loosen the setscrews on the pulleys and remove from either the motor or fan shaft using a two or three jaw puller.
- Remove any shaft imperfection such as setscrew mark using a file or emery cloth.
- Install the replacement pulleys, tightening all setscrews and bolts to the recommended torque rating (see chart), ensuring that they are properly aligned.
- Pulley alignment is achieved by moving the pulleys on their respective shafts or moving the entire motor until the pulleys are correctly aligned (see figure). Using a square with one edge parallel to the motor shaft adjust the pulleys until the other edge is parallel to the belts.
- Slip the belts over the pulleys then adjust the motor/ motor plate until the proper tension is reached (1/64" deflection, half way between pulley centers, per inch of belt span when pressed firmly).
- Tighten the motor plate/ motor adjusting nuts in place.

Belt Tension

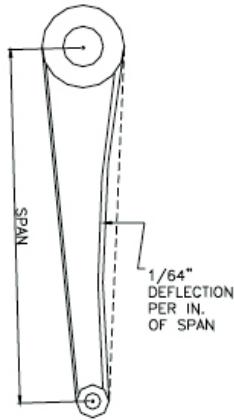

Pulley Alignment

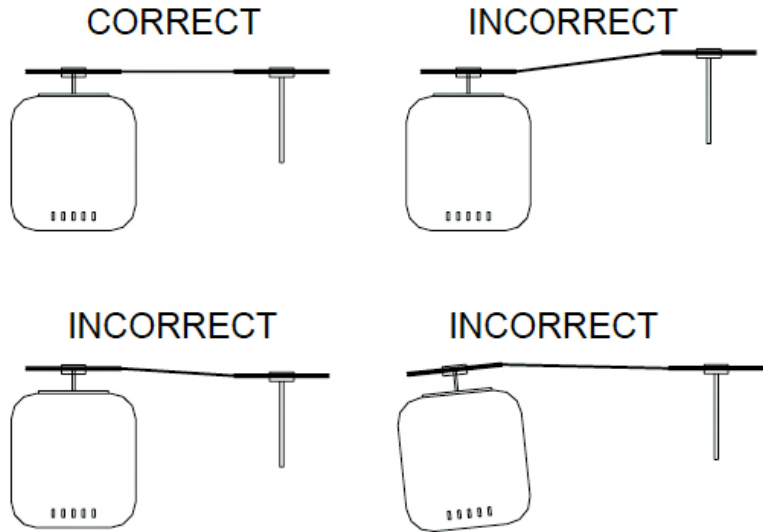

Recommended Torque for Setscrews/Bolts (inch/lbs)

SETSCREWS				HOLD DOWN BOLTS	
SIZE	HEX KEY	RECOMMENDED TORQUE INCH-LBS		SIZE	TORQUE INCH-LBS
		MIN	MAX		
NO.10	3/32"	28	33	3/8"-16	240
1/4"	1/8"	66	80	1/2"-13	600
5/16"	5/32"	126	156	5/8"-11	1200
3/8"	3/16"	228	275	3/4 "-10	2100
7/16"	7/32"	348	384	7/8"-9	2040
1/2"	1/4"	504	600	1"-8	3000
5/8"	5/16"	1104	1200	1-1/8"-7	4200
3/4"	3/8"	1440	1800	1-1/4"-7	6000

Bearings Replacement

Canarm/LFI Ltd. uses pillow block bearings.

- Remove belts (see above procedure)
- Remove fan from curb
- Remove shaft and bearing cover (RTA, RWTA)
- Before removing the bearings mark the positions of the fan blade, bearings and pulley on the shaft.
- Note the clearance between the fan blade and the venturi.
- Remove the pulley and fan blade from the shaft using a puller.
- Unbolt the bearings and remove the shaft and pillow blocks as one unit.
- Clean the shaft and remove any marks using a file or emery cloth then remove the bearings using a bearing puller.

- Inspect the shaft and replace if necessary.
 - Mount the new bearings on a section of the shaft that is not worn by tapping the bearings inner ring face using a soft mallet.
 - Align the setscrews on the bearings and then tighten one setscrew on each bearing.
 - Loosely install the bearings on the bearing mount.
 - Rotate the shaft to find the center of free movement.
 - Install the propeller adjusting the bearing location to center the blade in the venturi.
 - Tighten the bearing bolts to the proper torque rating (see chart)
 - Install the shaft and bearing cover (RTA, RWTA)
 - Turn the propeller by hand the propeller should rotate freely with the same resistance as before the bearing bolts were tightened.
 - Tighten all setscrews to the proper torque rating (see chart)
 - Install the pulley and adjust the belt tension.
 - Install on the roof curb
- Follow the start up steps as outlined above.

PARTS LIST

MODELS: RTA, RWTA

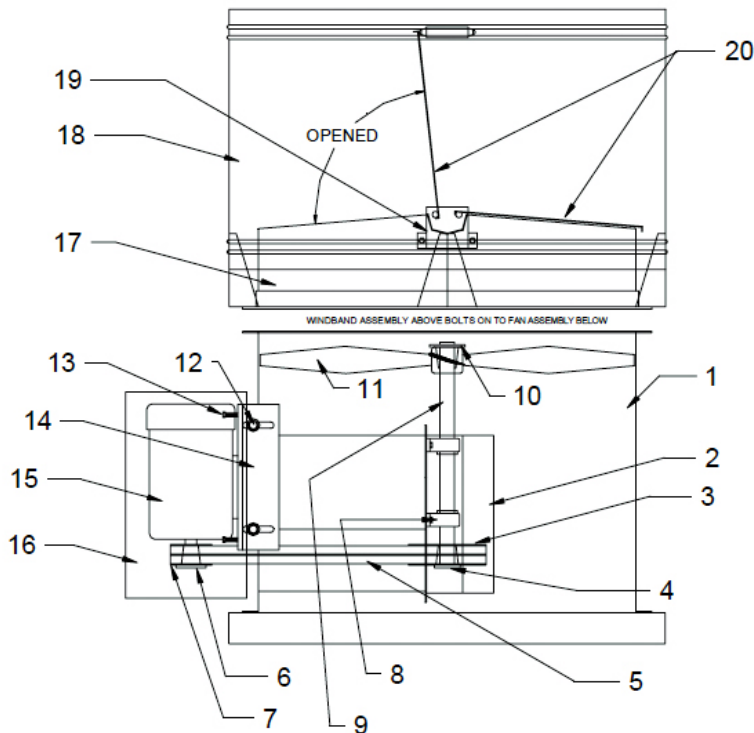

REPLACEMENT PARTS LIST

FAN ASSEMBLY

ITEM	DESCRIPTION	QUANTITY
1	FAN HOUSING	1
2	BEARING & SHAFT COVER	1
3	DRIVEN SHEAVE	1
4	DRIVEN SHEAVE BUSHING	1
5	V-BELTS	2
6	MOTOR SHEAVE BUSHING	1
7	MOTOR SHEAVE	1
8	PILLOW BLOCK BEARINGS	2
9	FAN SHAFT	1
10	PROPELLER BUSHING	1
11	PROPELLER	1
12	BASE LOCKING BOLTS	4
13	MOTOR BASE ADJ. BOLTS	4
14	MOTOR BASE	1
15	MOTOR	1
16	MOTOR COVER	1

DAMPER WINDBAND ASSEMBLY

ITEM	DESCRIPTION	QUANTITY
17	WELDED WINDBAND ASSEMBLY	1
18	WINDBAND	1
19	DAMPER BRACKET	2
20	BUTTERFLY DAMPERS	2

**PARTS LIST
MODELS: RB**

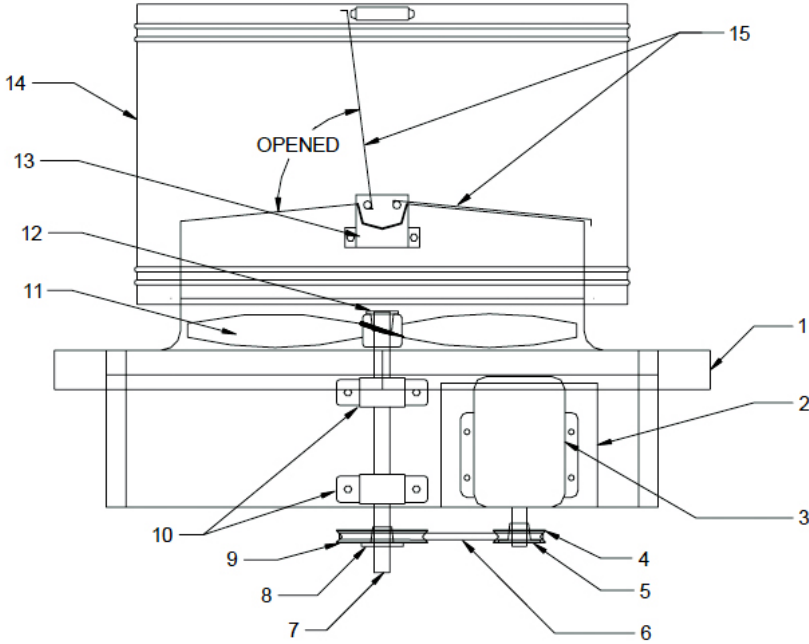

REPLACEMENT PARTS LIST

ITEM	DESCRIPTION	QUANTITY
1	FAN HOUSING	1
2	SLIDE BASE	1
3	MOTOR	1
4	MOTOR SHEAVE	1
5	MOTOR SHEAVE BUSHING	1
6	V-BELT	1
7	FAN SHAFT	1
8	DRIVEN SHEAVE BUSHING	1
9	DRIVEN SHEAVE	1
10	PILLOW BLOCK BEARINGS	2
11	PROPELLER	1
12	PROPELLER BUSHING	1
13	DAMPER BRACKETS	2
14	WIND BAND	1
15	BUTTERFLY DAMPERS	2

**PARTS LIST
MODELS: RD**

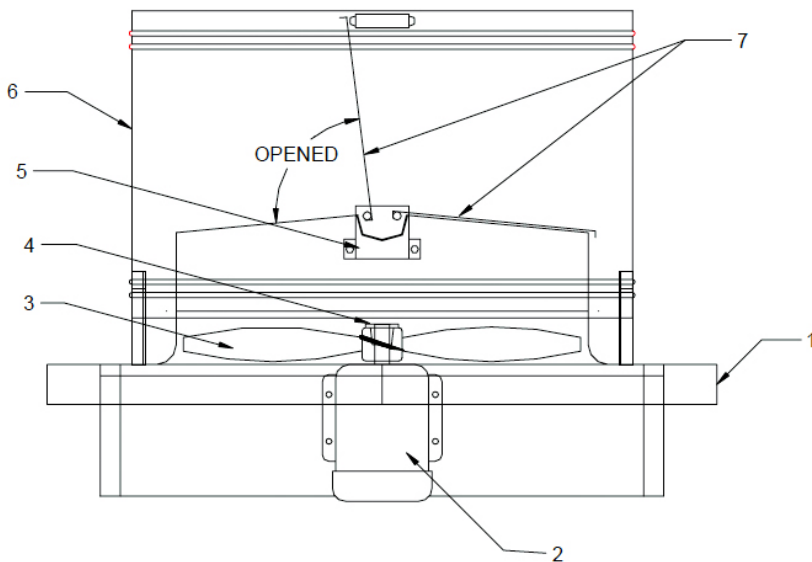

REPLACEMENT PARTS LIST

ITEM	DESCRIPTION	QUANTITY
1	FAN HOUSING	1
2	MOTOR	1
3	PROPELLER	1
4	PROPELLER BUSHING	1
5	DAMPER BRACKETS	2
6	WIND BAND	1
7	BUTTERFLY DAMPERS	2

FAN TROUBLE SHOOTING GUIDE

PROBLEM	POSSIBLE CAUSES
VIBRATION	Impeller or sheaves loose Belts not tensioned properly Bent shaft Out of balance impeller Loose fasteners Loose or worn bearings Drive misalignment Fan not properly installed Mismatched belts Out of balance sheaves Improper fan installation
MOTOR OVERLOADING	Static pressure higher than design Impeller rotating in the wrong direction Improper fan speed Defective motor Fan speed higher than design
TOO MUCH AIR	Filters missing Static pressure lower than design Fan speed higher than design
FAN DOES NOT OPERATE	Lack of electricity to the fan Fan wired improperly Broken or missing belt Missing or blown fuses Overload protection has broken circuit Defective motor
EXCESSIVE NOISE	Impeller or sheaves loose Belts not properly tensioned Sheaves not properly aligned Impeller out of balance Sheaves out of balance Bent shaft Bearings defective or need lubrication Worn belts Vibration or lack of isolation Loose fasteners High velocity air

WARRANTY

Canarm/LFI Limited warrants this equipment to be free from defects in material and workmanship for a period of one year from the date of sale. The motor manufacturer warrants motors for a period of one year. Any fans or parts, which prove to be defective during the warranty period, will be repaired or replaced at our option when returned to our factory transportation prepaid. A return authorization number, that is to be obtained our customer service department, must accompany all returns to Canarm/LFI Limited. Canarm/LFI Limited will not be responsible for any removal or installation costs.

CANARM LTD. – CORPORATE HEAD OFFICE
 2157 Parkedale Avenue, Brockville, Ontario K6V 5V6 Canada Phone: (613) 342-5424 Fax: (613) 342-8437
 Web Site: www.canarm.com